



## INSTALLATION INSTRUCTIONS FOR PART 99-7503

### APPLICATIONS

2003-2005 Mazda 6

# 99-7503



#### KIT FEATURES

- DIN Head Unit Provision
- ISO DIN Head Unit Provision

#### KIT COMPONENTS

A) Radio/Climate Control Housing Assembly | B) ISO Brackets | C) ISO Trim plate | D) Harnesses

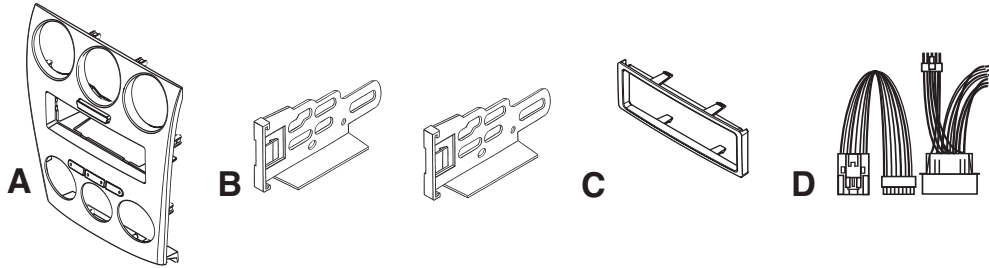

#### TOOLS REQUIRED:

Phillips Screwdriver | Small Flat Blade Screwdriver | Socket Wrench

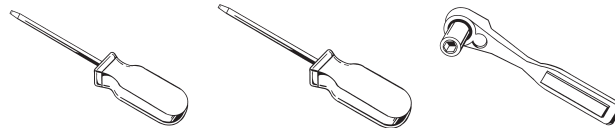

1-800-221-0932



[www.metraonline.com](http://www.metraonline.com)

© COPYRIGHT 2004 METRA ELECTRONICS CORPORATION



# **TABLE OF CONTENTS**

***Dash Disassembly . . . . . 1-5***  
***Electronic Climate Control . . . . . 1-2***  
***Manual Climate Control . . . . . 3-5***

***Kit Assembly . . . . . 6-8***  
***Electronic Climate Control . . . . . 6***  
***Manual Climate Control . . . . . 7-8***

***Felt Tape Application . . . . . 9***

***Display Customization . . . . . 10***

***Final Assembly . . . . . 11***

## 2003-2004 MAZDA 6 Electronic Climate Control

- 1 Disconnect the negative battery terminal to prevent an accidental short circuit.
- 2 Unscrew the shift knob counter clockwise to remove. (Figure A)
- 3 Unclip and remove the cup holder/parking brake cover and shifter cover as one unit. (Figure B)
- 4 Remove (2) Phillips screws from the bottom of the radio/climate control panel. (Figure C)
- 5 Open glove box, squeeze sides together and let open fully then remove (1) 10 MM bolt from the side of the radio bracket. (Figure D)

A

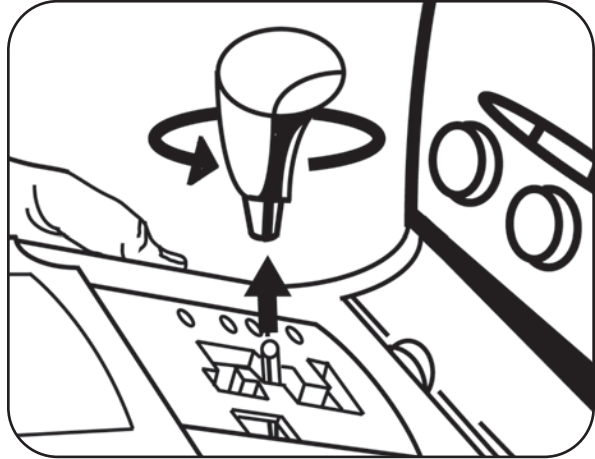

B

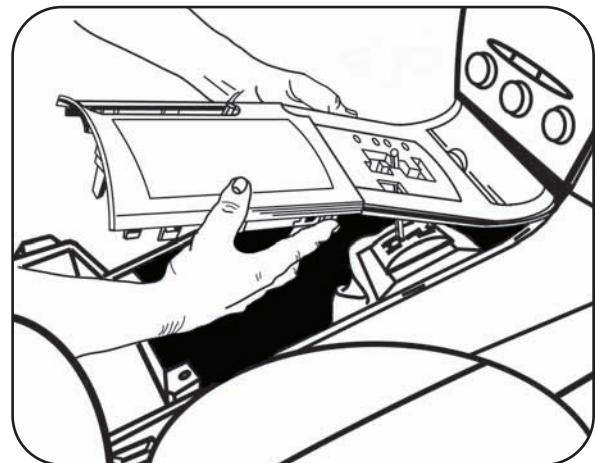

C

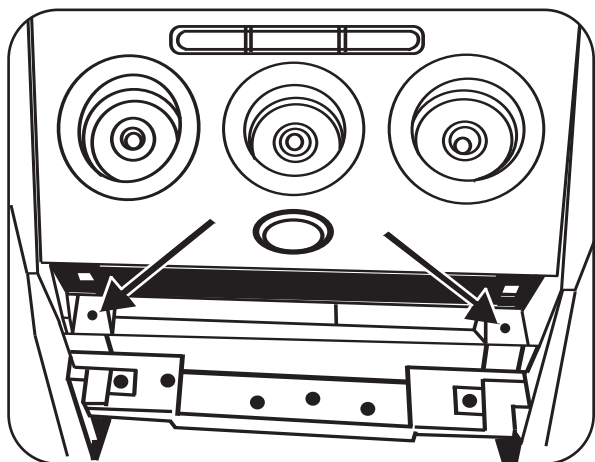

D

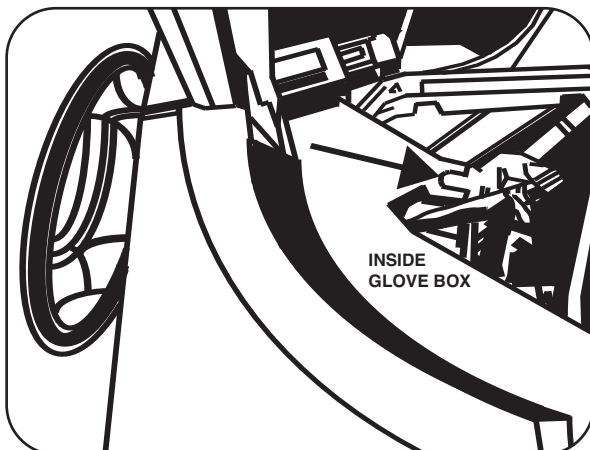

## 2003-2004 MAZDA 6 Electronic Climate Control

**6** Unsnap and remove radio/climate control panel including climate control vents at the top. (Figure E)

**7** Remove (4) Phillips screws securing vents to radio/climate control panel to remove. (Figure F)

**8** Remove (8) Phillips screws securing the electronic climate control to the radio/climate control panel to remove. (Figure G)

**9** Remove (4) Phillips screws securing the radio display harness bracket to the radio chassis then unclip and remove the radio display harness. (Figure H)

**E**

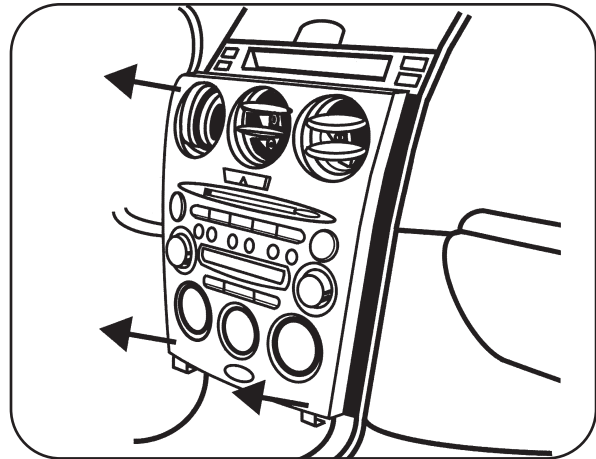

**F**

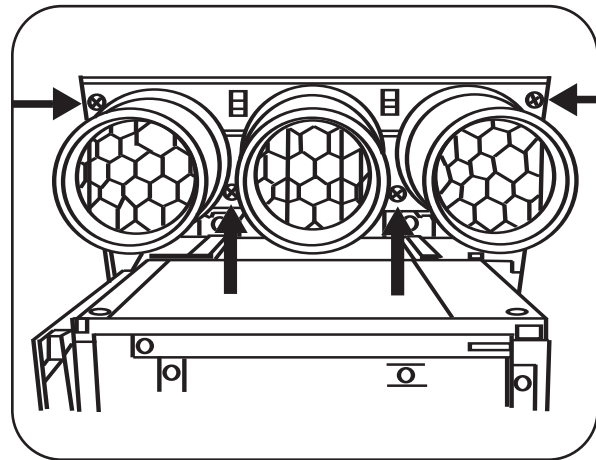

**G**

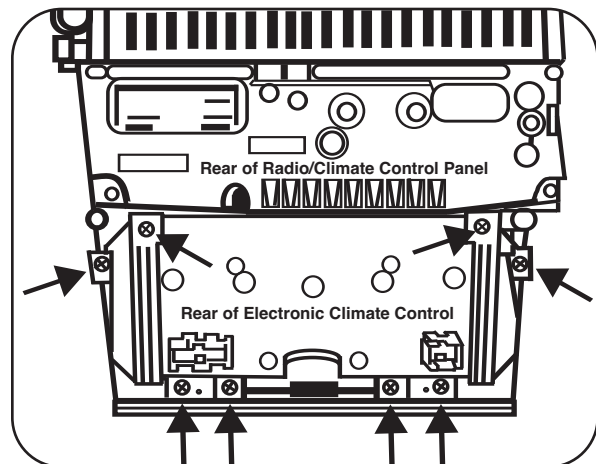

**H**

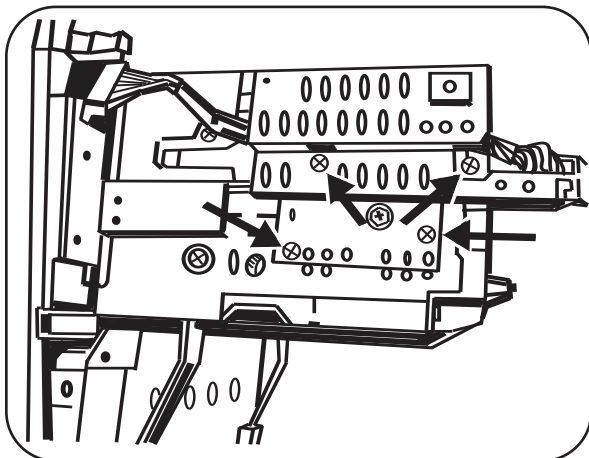

## 2003-2004 MAZDA 6 Manual Climate Control

- 1 Disconnect the negative battery terminal to prevent an accidental short circuit.
- 2 Unscrew the shift knob counter clockwise to remove. (Figure A)
- 3 Unclip and remove the cup holder/parking brake cover and shifter cover as one unit. (Figure B)
- 4 Remove (2) Phillips screws from the bottom of the radio/climate control panel. (Figure C)
- 5 Pull the climate control knobs off and remove (2) Phillips screws from behind knobs. (Figure D)

A



B

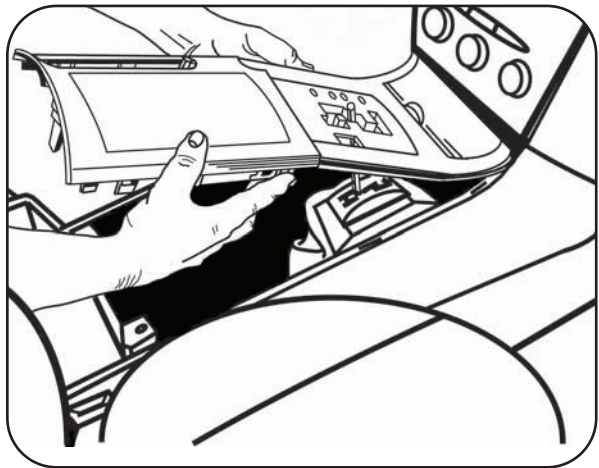

D

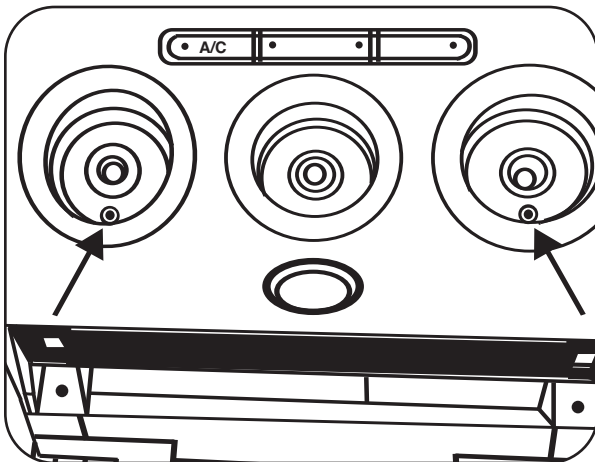

C

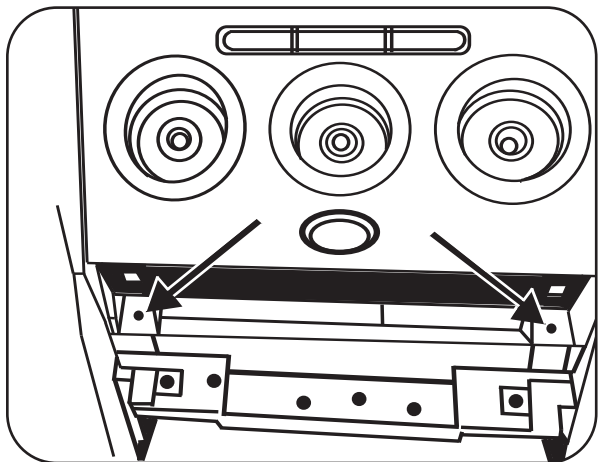

## 2003-2004 MAZDA 6 Manual Climate Control

**6** Open glove box, squeeze sides together and let open fully then remove (1) 10 MM bolt from the side of the radio bracket. (Figure E)

E

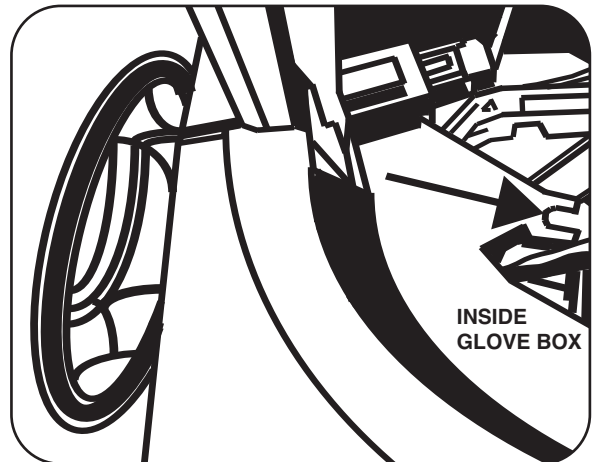

**7** Unsnap and remove radio/climate control panel including climate control vents at the top. (Figure F)

F

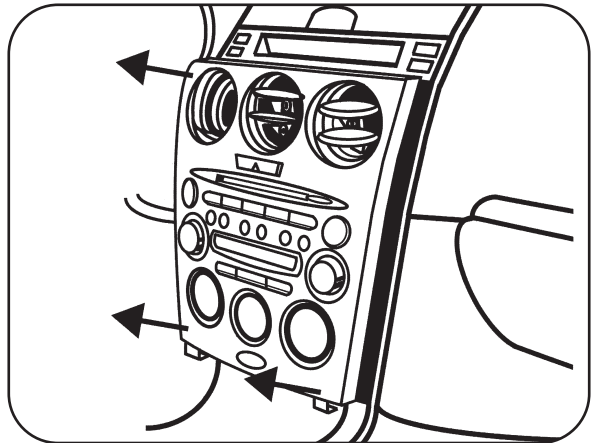

**8** Remove (4) Phillips screws securing vents to radio/climate control panel to remove. (Figure G)

**9** Remove the (2) small Phillips screws securing the light bulb boards on each side of the backlight dispersion bar. **Note:** Notice how they are positioned in the backlight dispersion bar as they will be placed in the 99-7503 the same way. (Figure H)

G

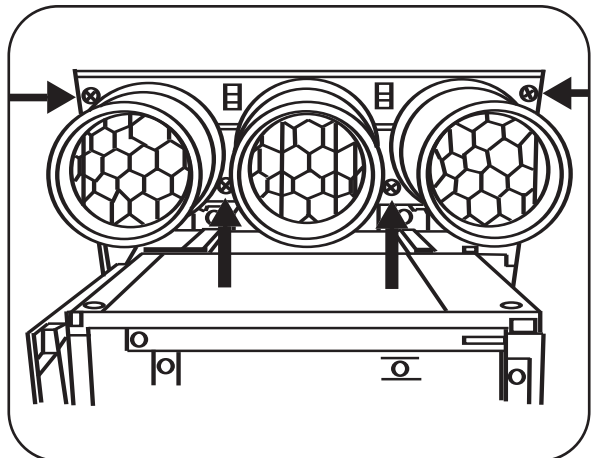

H

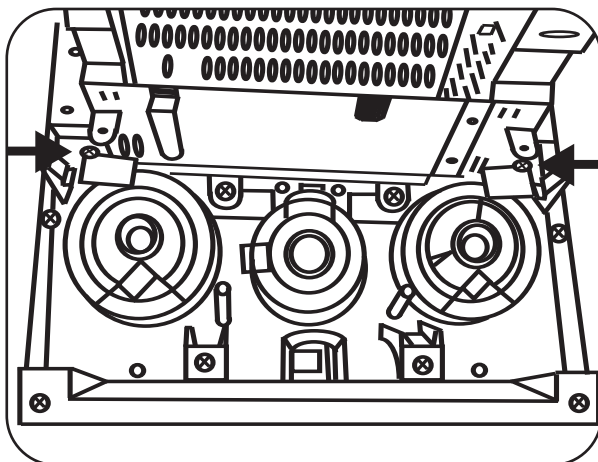

## 2003-2004 MAZDA 6 Manual Climate Control

- 10 Remove (4) Phillips screws securing backlight dispersion bar and knob trim bezels. (Figure I)
- 11 Push the bottom edges of the knob trim bezels from the front side to the back and slide both pieces out as one unit. (Figure J)
- 12 Remove (4) Phillips screws securing the radio display harness bracket to the radio chassis then unclip and remove the radio display harness. (Figure K)

I

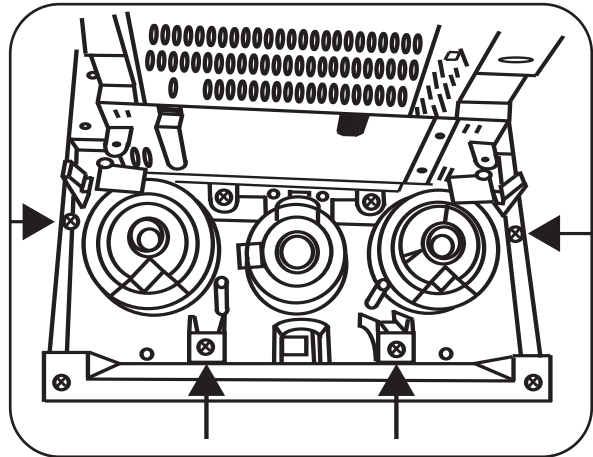

J

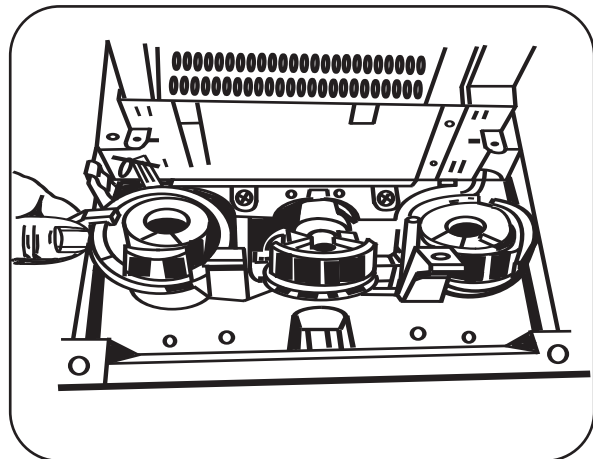

K

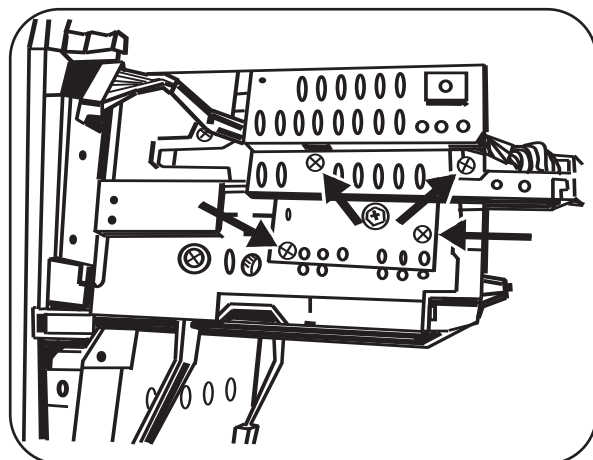

## 2003-2004 MAZDA 6

### Electronic Climate Control

- 1 Clip the climate control knob outer trim ring panel into the 99-7503 housing. (Figure A)
  
- 2 Align the screw holes in the climate control and the radio housing panel then push the climate control onto the radio housing panel. (Figure B)
  
- 3 Secure the climate control with the factory hardware removed in step 8 of the dash disassembly for electronic climate control cars.
  
- 3 Unclip and remove the small oval cover plate at the bottom center of the factory radio and insert into the 99-7503 radio housing. (Figure C)

**Note:** The 16 position to 16 position harness supplied with the 99-7503 will NOT be used in vehicles with electronic climate controls. (Figure D)

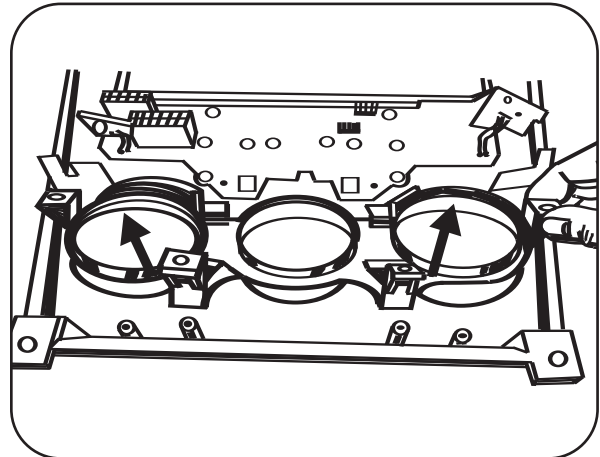
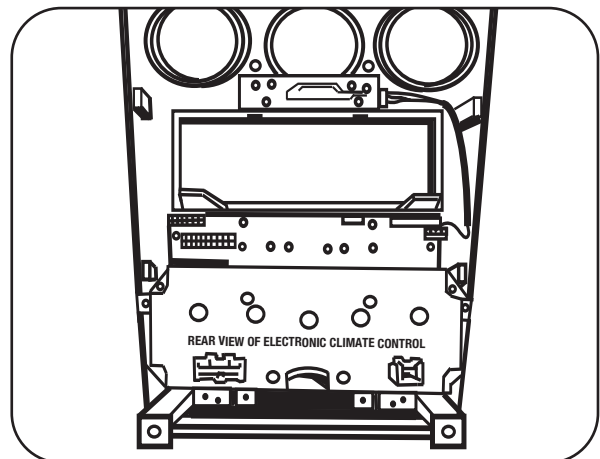
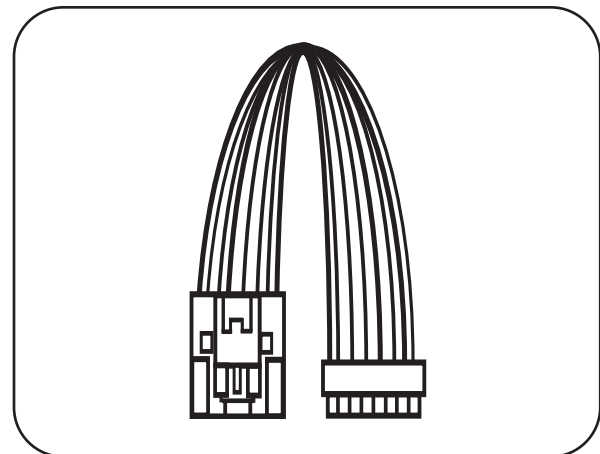
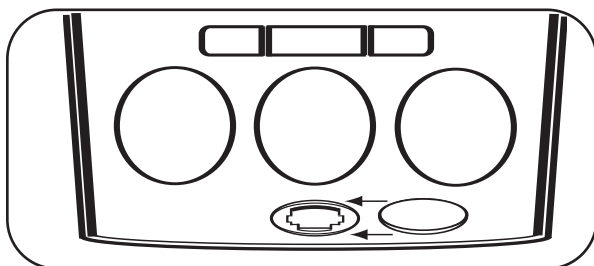
**A**

**B**

**D**

**C**

## 2003-2004 MAZDA 6

### Manual Climate Control

**1** Put the climate control knob outer trim panel and the backlight dispersion bar together and clip into the radio housing panel as one unit.  
**Note:** You may have to push down slightly on the middle of the unit to ease in positioning it into the kit.  
 (Figure A, B, C)

**2** Secure the unit with the factory hardware removed in step 10 of the manual climate control dash disassembly.

**3** Secure the light bulb boards on each side of the backlight dispersion bar using the factory hardware removed in step 9 in manual climate control dash disassembly. (Figure D)

**4** Unclip and remove the small oval cover plate at the bottom center of the factory radio and insert into the 99-7503 radio housing. (Figure E)

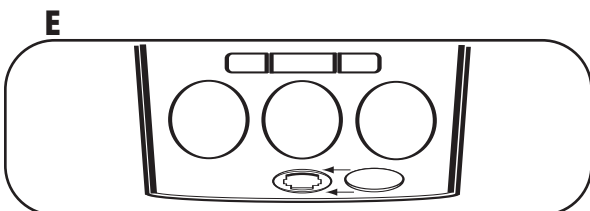
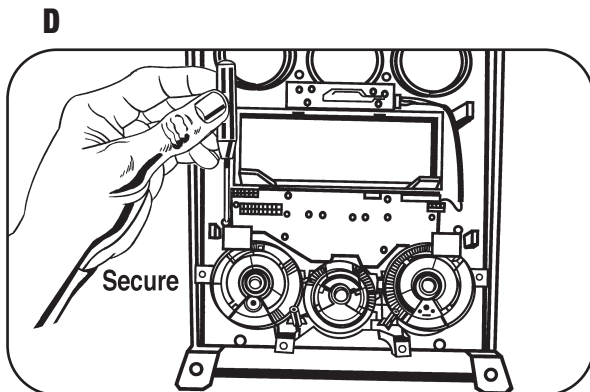
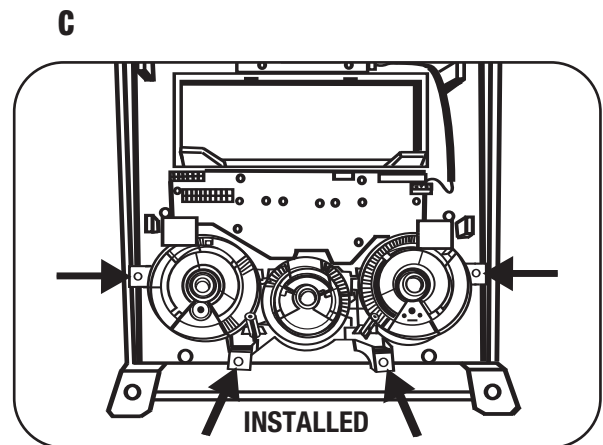
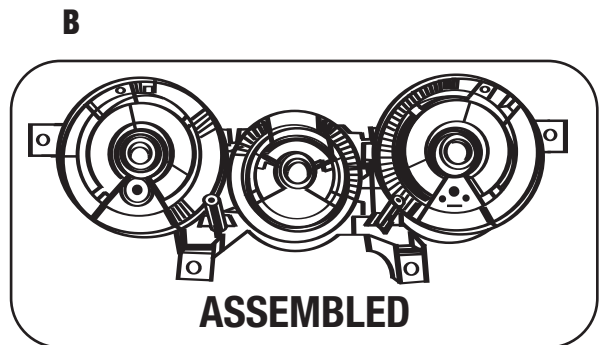
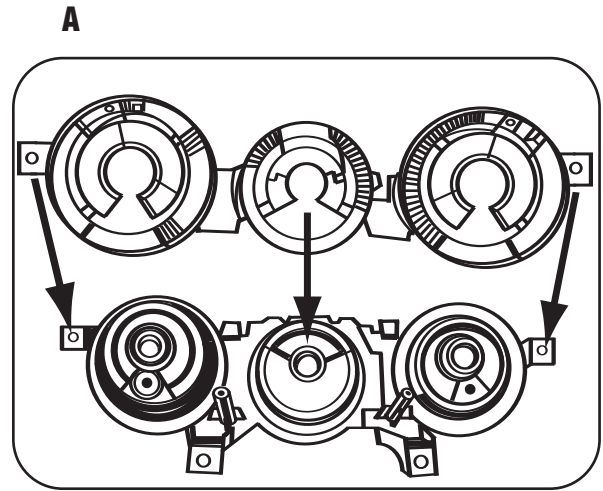

**Note:** The 16 position to 16 position harness supplied with the 99-7503 WILL be used in vehicles with manual climate controls. (Figure F)

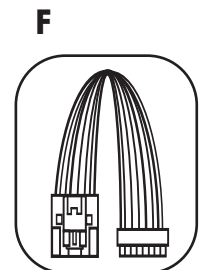

## DIN HEAD UNIT PROVISION

- 1 Slide the DIN cage into the Radio Housing and secure by bending the metal locking tabs down. (Figure A)
- 2 Slide the aftermarket head unit into the DIN cage until secure. (Figure B)

**A**

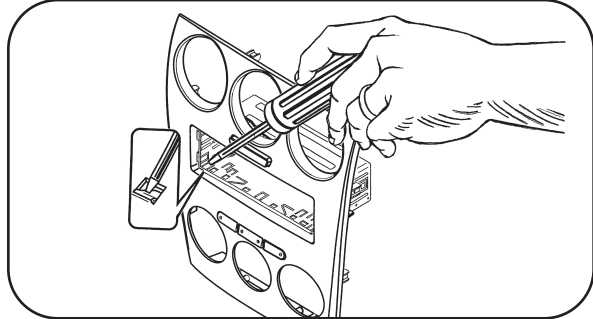

- 3 Snap the Trim plate into the Radio Housing.(Figure B)

**B**

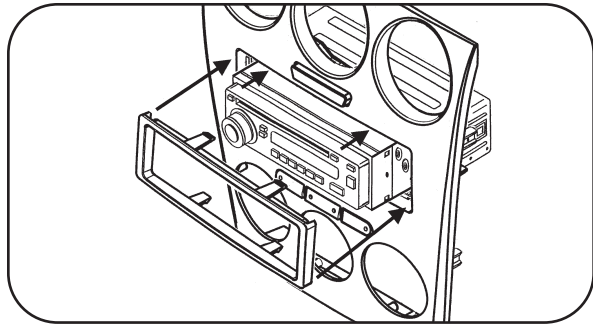

## ISO DIN HEAD UNIT PROVISION

- 1 Mount the ISO Brackets to the head unit with the screws supplied with the unit. (Figure A)
- 2 Slide the head unit into the radio opening until the side clips engage. (Figure B)
- 3 Snap the Trim plate into the Radio Housing.(Figure B)

**A**

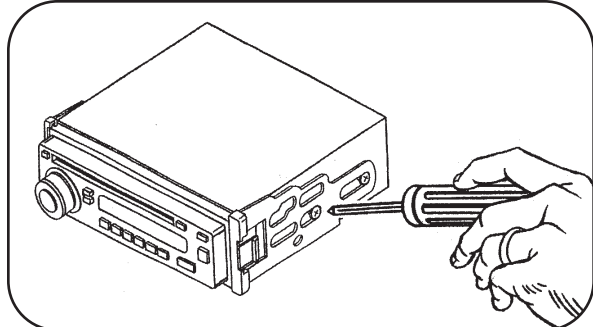

**B**

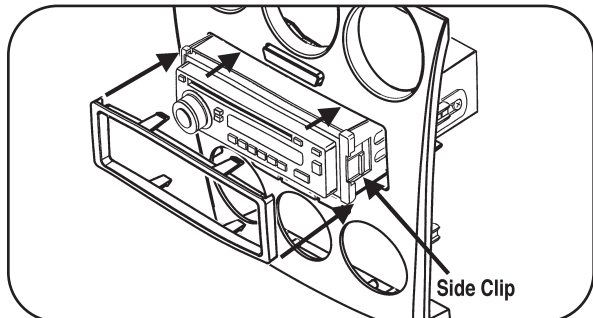

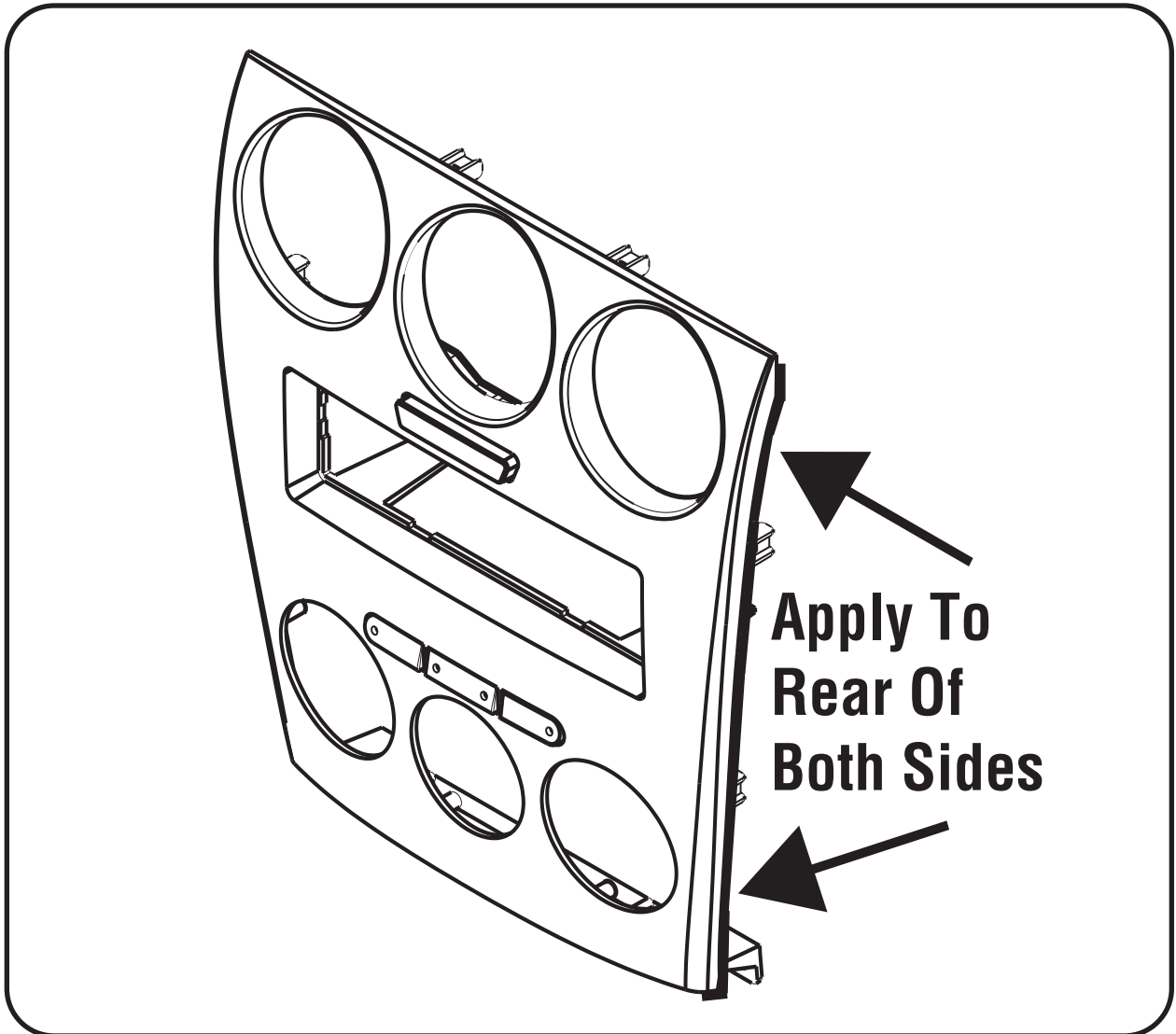
**FELT TAPE APPLICATION**

Note: Due to differences in factory tolerances you may need to apply the provided felt tape to the edge of the 99-7503 radio housing to relieve backlight bleed through.

1. Looking at edge of radio housing apply felt tape to inner edge (toward back of kit). If it is positioned to closely to the outer edge you may be able to see it once it is in the dash.

## **DISPLAY CUSTOMIZATION**

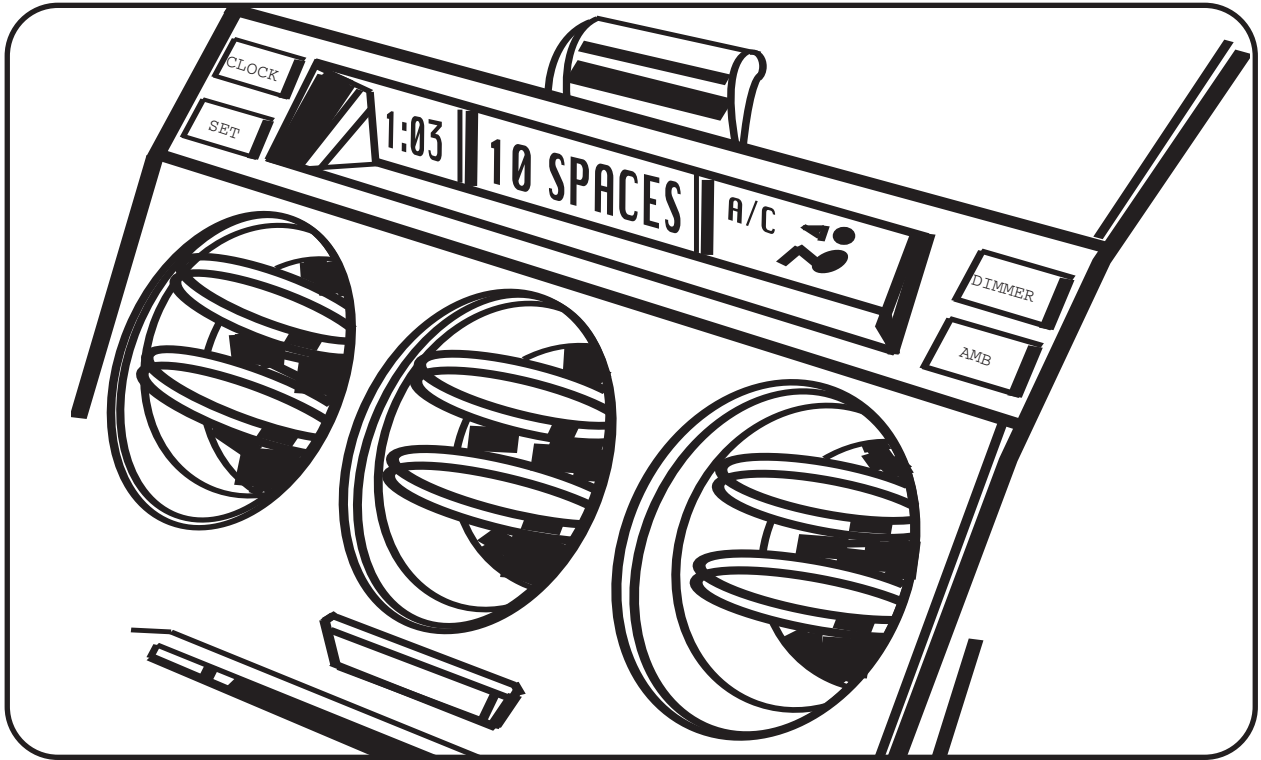

1. Press and hold the **Clock button** in the factory display until **“Set Text”** is displayed, then release the button. Settings will begin with the first character location. Use the **Set button** to select the desired character then press the **AMB button** to select the next character location. There are 10 available character locations.
2. Once the desired text is entered if you do not touch any buttons for 10 seconds the display will read **“Saved Text”** and your text will be saved.
3. To set the clock press and hold the **Clock button** until **“Hr. Adjust”** is displayed then use the **Set button** to select the desired hour.
4. Press the **Clock button** again and the display will read **“Min. Adjust”** then use the **Set button** to select the desired minutes.

Note: If equipped with a **Dimmer button** it will still function as normal.

## FINAL WIRING and ASSEMBLY

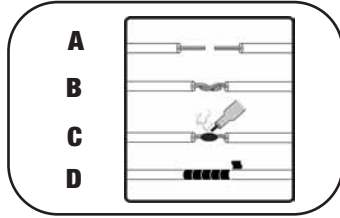

- A) Strip wire ends back 1/2"**
- B) Twist ends together**
- C) Solder**
- D) Tape**

- 1** Locate the factory wiring harness in the dash. Use the supplied wire harnesses and make the connection as shown. (Isolate and individually tape off the ends of any unused wires to prevent electrical short circuit.)

Make wiring connections using the EIA color code chart shown below and the instructions included with the head unit. Metra recommends making connections as shown below; Strip, Splice, Solder, Tape. Isolate and individually tape off ends of any unused wires to prevent electrical short circuit.

### METRA / EIA WIRING CODE

12V Ignition / Acc . . . Red	Right Front (+) . . . . . Gray
12V Batt / Memory . Yellow	Right Front (-) . . . . . Gray / Black
Ground . . . . . Black*	Left Front (+) . . . . . White
Power Antenna . . . . . Blue	Left Front (-) . . . . . White / Black
Amp Turn-On . . . . . Blue / White	Right Rear (+) . . . . . Violet
Amp Ground . . . . . Black / White	Right Rear (-) . . . . . Violet / Black
Illumination . . . . . Orange	Left Rear (+) . . . . . Green
Dimmer . . . . . Orange / White	Left Rear (-) . . . . . Green / Black

**\*NOTE:** When Black a wire is not present, ground radio to vehicle chassis.

All colors may not be present on all leads due to manufacturer's specifications.

- 2** Plug the 5 way connector (supplied with the 99-7503) into location 1 on the back of the 99-7503 housing (see diagram).
- 3** Plug the 16 way connector that you removed from the factory radio into location 2 on the back of the 99-7503 housing (see diagram).
- 4** On manual climate control vehicles only, plug the 16 way connector (supplied with the 99-7503) into location 3 on the back of the 99-7503 housing (see diagram). Automatic climate control vehicles will not use this harness.
- 5** Re-connect the negative battery terminal and test the unit for proper operation.
- 6** Reassemble radio and dash assemblies in reverse order of disassembly.

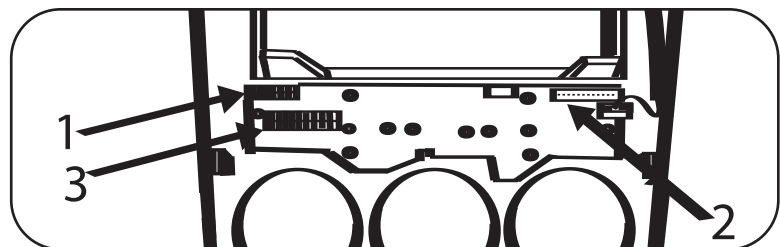





**INST997503**



1-800-221-0932



[www.metraonline.com](http://www.metraonline.com)

REV. 09/09/05

© COPYRIGHT 2004 METRA ELECTRONICS CORPORATION

INST99-7503